

## CAT50 & Straight Shank ER40 Collet Chucks

(Balanced to G2.5@15,000 RPM)

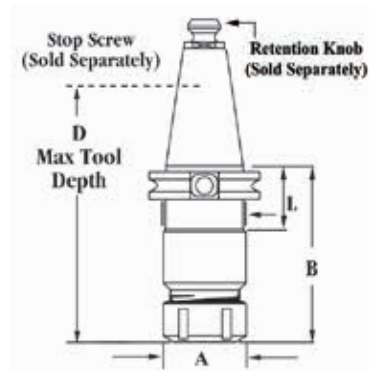

- Small diameter nose well-suited for working in close quarters
- Increased flexibility for milling, drilling, and reaming
- Flush precision collet nut, grips tool close to cutting edge for accuracy and rigidity
- Concentric to .0002" TIR puts tool precisely on spindle center line
- AT3 or better shank taper allows for accurate, rigid toolholder-to-spindle mount
- Wide range collets reduce collet and toolholder inventories
- Fully ground flange and V-groove is easy on tool changers for less spindle and changer maintenance
- Through spindle coolant standard
- **ER40 Collets found on pages 610-612.**



CAT50 ER40 Collet Chucks							
Capacity	Taper	A	Gage Length (B)	D	L	Max. Nosepiece Torque	Part #
.086-1.023	CAT50	2.48	4.00	4.0	1.38	72 ft lbs	<a href="#">RC5ER404000</a>
.086-1.023	CAT50	2.48	6.00	5.0	1.38	72 ft lbs	<a href="#">RC5ER406000</a>

ER40 Straight Shank Collet Extension						
A	B	D	L	Photo	Dimensions	Part #
2.48	6.0	1.25	3.50			<a href="#">RSSER40600</a>

ER40 Parts & Accessories			
Description	Photo	Dimensions	Part #
ER40 Replacement Nosepiece			<a href="#">RER40NPA</a>
ER40 Collet Wrench†			<a href="#">RER40W</a>
ER40 Stop Screw			<a href="#">RER40SS</a>
ER40 Stop Screw Coolant Thru			<a href="#">RER40SSC</a>

†Required for assembly.